

### Spherical roller bearings, cylindrical and tapered bore

Principal dimensions			Basic load ratings		Fatigue load limit Pu	Speed ratings		Mass	Designation
d	D	B	dynamic	static		Reference speed	Limiting speed		
mm			kN		kN	r/min		kg	-
95	200	45	425	490	49	3400	4500	6,95	21319 EK *

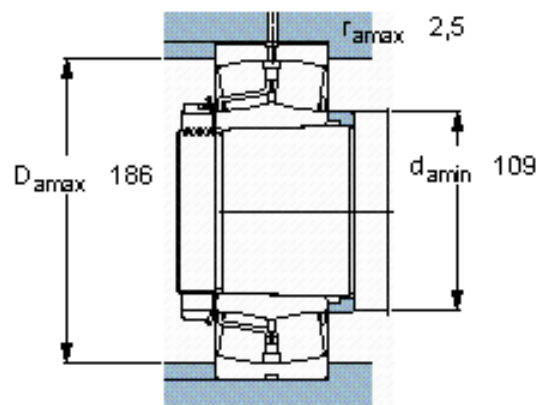
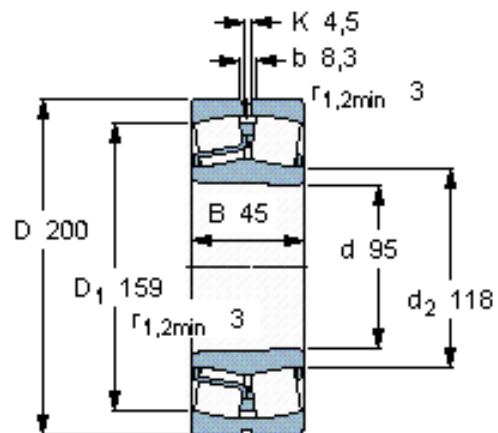

#### Calculation factors

$e$  0,24  
 $Y_1$  2,8  
 $Y_2$  4,2  
 $Y_0$  2,8