

Spherical roller bearings, cylindrical and tapered bore

| Principal dimensions | | | Basic load ratings | | Fatigue load limit Pu | Speed ratings | | Mass | Designation |
|----------------------|-----|----|--------------------|--------|--------------------------|-----------------|----------------|------|-------------|
| d | D | B | dynamic | static | | Reference speed | Limiting speed | | |
| mm | | | kN | | kN | r/min | | kg | - |
| 85 | 180 | 41 | 325 | 375 | 39 | 3800 | 5300 | 5,20 | 21317 E * |

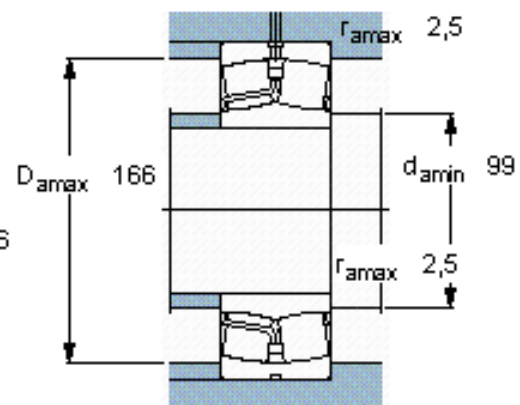
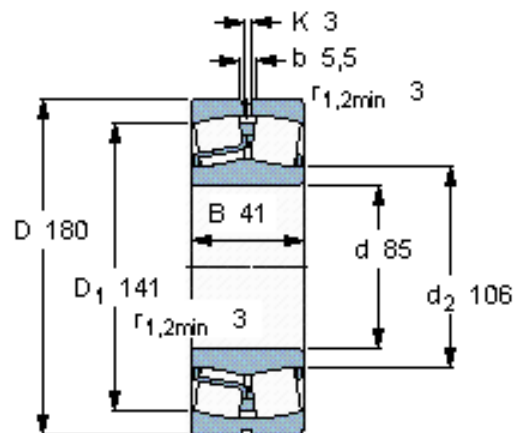

Calculation factors

e 0,24
 Y_1 2,8
 Y_2 4,2
 Y_0 2,8